

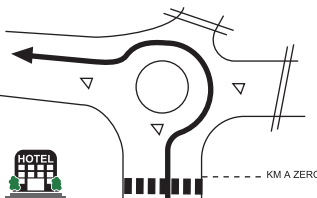

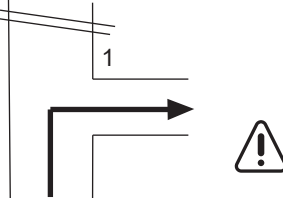

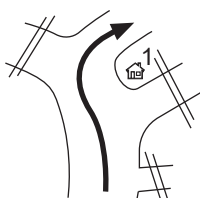





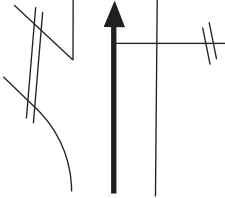
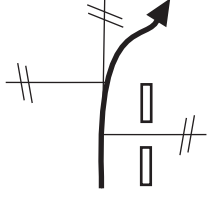
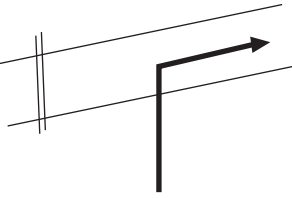
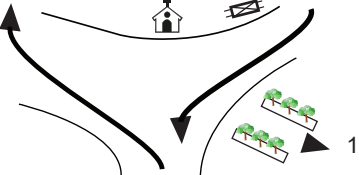
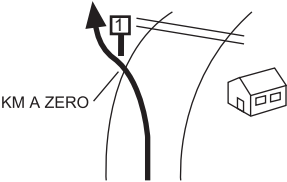

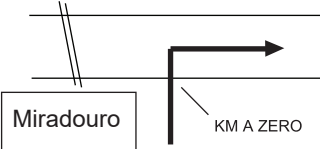
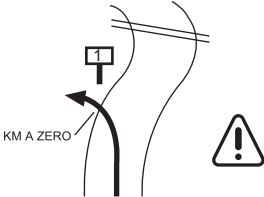
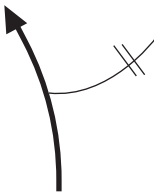
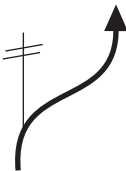
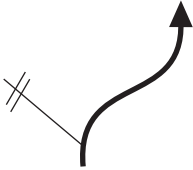
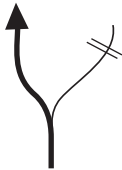

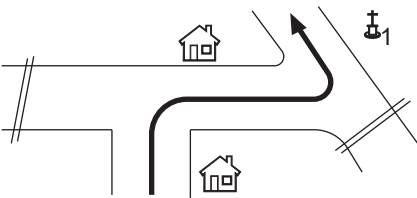
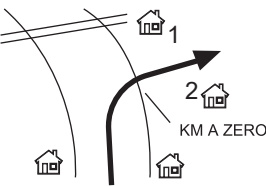
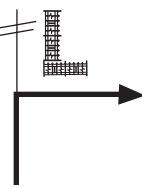
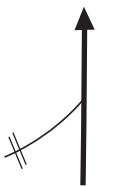
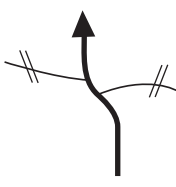

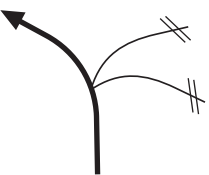
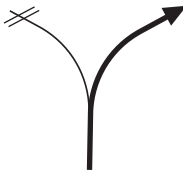
NOTA	PARCIAIS	TOTAIS	DIREÇÃO	OBSERVAÇÕES
1	0,000 /	0,000 /		<b>FREIXO DE ESPADA À CINTA PÔR KM A ZERO</b>
2	0,100	0,100		1 - Rua do Carrascal
3	0,100	0,200		1 - Casa branca
4	0,100	0,300		1 - Rua Bispo José Maria Teixeira <b>SOBE ASFALTO PRINCIPAL</b>
5	0,100	0,400		<b>DESCE PISO DEGRADADO POUCO DEPOIS TERRA ESTREITO!</b>
6	0,800	1,200		<b>SOBE</b>
7	1,300	2,500		<b>ENTRA E SEGUE ASFALTO</b>
8	0,750	3,250		1 - Miradouro <b>CAPELA Nº SRA. DE MONTES ERMOS CONTORNA, ADMIRE PAISAGEM E DESÇA E SIGA A ESTRADA POR ONDE VEIO</b>

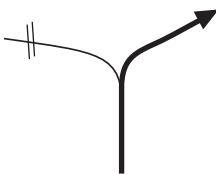
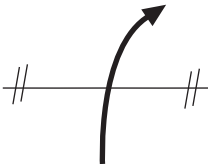
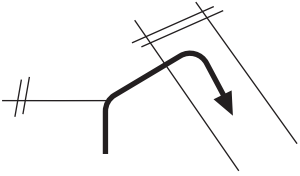
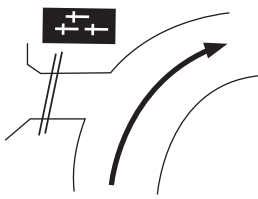
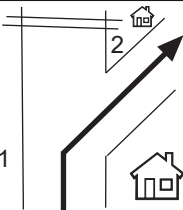
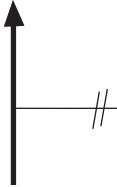
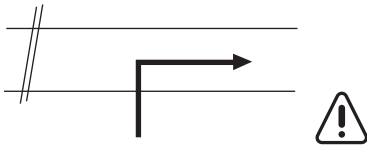
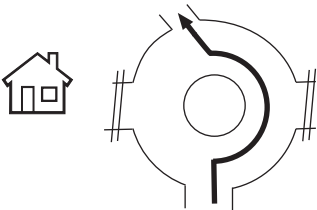
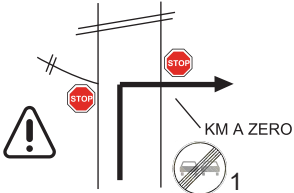

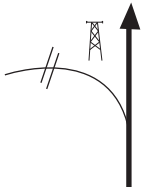

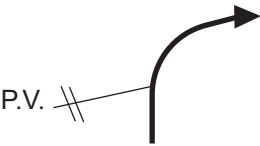
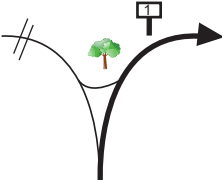

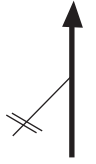
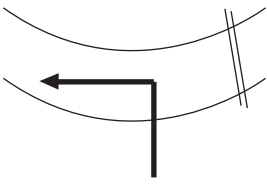
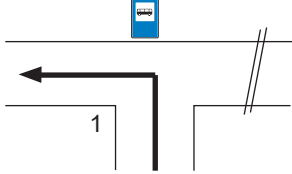
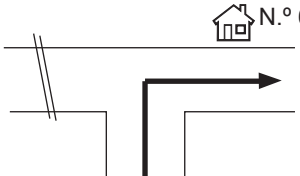
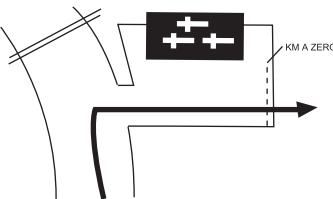
NOTA	PARCIAIS	TOTAIS	DIREÇÃO	OBSERVAÇÕES
1	1,100 / 0,000	4,350 / 0,000		1 - Placa de caça  <b>ENTRA TERRA PÔR KM A ZERO SOBE P.P.</b>
2	1,000	1,000		<b>DESCE P.P.</b>
3	0,200	1,200		<b>PODE IR PRIMEIRO À ESQUERDA OBSERVAR PAISAGEM NO MIRADOURO DE FREIXO DEPOIS, NESTE PONTO, COLOCA KM A ZERO E SEGUE EN221</b>
4	1,100 / 0,000	2,300 / 0,000		1 - Placa Portugal 2020  <b>ATT!! ENTRA TERRA PÔR KM A ZERO SEGUE P.P.</b>
5	0,300	0,300		<b>CONTINUA P.P.</b>
6	0,700	1,000		<b>DESCIDA ÍNGREME EXPERIMENTE DSR</b>
7	0,900	1,900		<b>DESCE P.P.</b>
8	0,500	2,400		<b>CONTINUA P.P.</b>

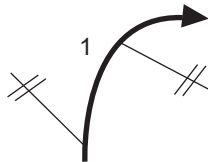
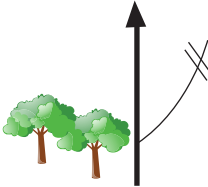

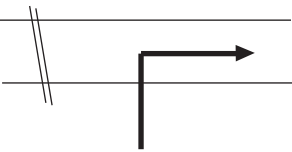
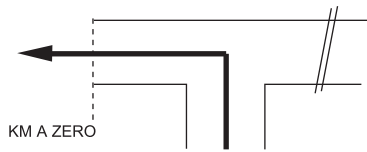
NOTA	PARCIAIS	TOTAIS	DIREÇÃO	OBSERVAÇÕES
1	0,400	2,800		<b>ENTRA E SOBE EMPEDRADO</b>
2	0,100	2,900		1 - Nicho de Nª Sra. <b>ENTRA E SEGUE ASFALTO</b>
3	0,400 0,000	3,300 0,000		1 - Rua do Canto 2 - Caminho do Colado Mourisco <b>ENTRA TERRA PÔR KM A ZERO SEGUE P.P.</b>
4	0,300	0,300		<b>DESCE P.P.</b>
5	0,300	0,600		<b>CONTINUA P.P.</b>
6	0,300	0,900		<b>SOBE P.P.</b>
7	0,300	1,200		<b>CONTINUA P.P.</b>
8	0,100	1,300		<b>DESCE P.P.</b>

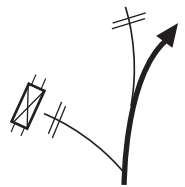
NOTA	PARCIAIS	TOTAIS	DIREÇÃO	OBSERVAÇÕES
1	0,100	1,400		<b>CONTINUA A DESCER P.P.</b>
2	0,800	2,200		<b>CONTINUA P.P.</b>
3	0,100	2,300		<b>SOBE P.P.</b>
4	0,600	2,900		<b>SOBE P.P.</b>
5	0,400	3,300		<b>SOBE P.P. E ENTRA E SEGUE ASFALTO ESTREITO</b>
6	0,600	3,900		<b>CONTINUA ASFALTO PRINCIPAL E ATRAVESSA MACIEIRINHA</b>
7	1,100	5,000		1 - Caixote do lixo 2 - Amendoal <b>SOBE RUA DA FONTINHA POUCO DEPOIS TERRA</b>
8	0,300	5,300		

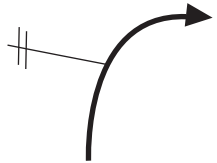
NOTA	PARCIAIS	TOTAIS	DIREÇÃO	OBSERVAÇÕES
1	0,400	5,700		<b>ENTRA EN220 ATT!!</b>
2	1,100	6,800		<b>DIR BRAGANÇA / MOGADOURO ENTRA EN221</b>
3	1,200 0,000	8,000 0,000		1 - Após sinal de fim de proibição ultrapassagem  <b>ENTRA TERRA PÔR KM A ZERO SOBE P.P.</b>
4	0,200	0,200		
5	0,200	0,400		<b>CONTINUA P.P.</b>
6	0,900	1,300		
7	1,200	2,500		<b>SOBE P.P.</b>
8	0,200	2,700		1 - Placa Informativa  <b>DESCE P.P.</b>

NOTA	PARCIAIS	TOTAIS	DIREÇÃO	OBSERVAÇÕES
1	0,700	3,400		
2	0,300	3,700		<b>ENTRA E DESCE ASFALTO</b>
3	1,300	5,000		1 - Placa Bem- Vindo à Freguesia de Mazouco <b>DESCE ASFALTO PRINCIPAL DIR. GRAVURA RUPESTRE POUCO DEPOIS EMPEDRADO SEMPRE DIR. GRAVOURA RUPESTRE</b>
4	0,400	5,400		<b>DIR. GRAVURA RUPESTRE DESCE EMPEDRADO SEGUE SEMPRE DIR GRAVURA RUPESTRE</b>
5	0,600 0,000	6,000 0,000		<b>JÁ EM ASFALTO PÔR KM A ZERO ENTRA E DESCE TERRA SEGUE P.P.</b>
6	1,000	1,000		<b>DESCE P.P.</b>
7	1,700	2,700		1 - Admire Rio Douro
8	1,100	3,800		<b>CONTINUA P.P. AO LONGO DO RIO DOURO</b>

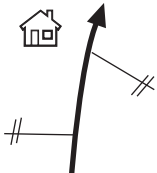
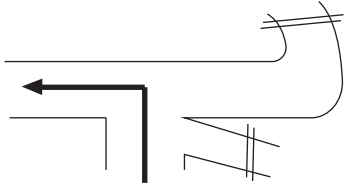
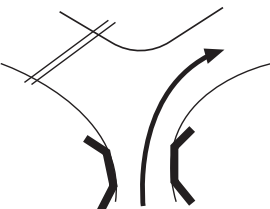
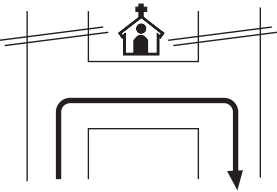
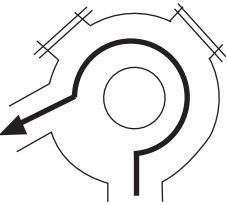
NOTA	PARCIAIS	TOTAIS	DIREÇÃO	OBSERVAÇÕES
1	0,900	<b>4,700</b>		<b>ENTRA E DESCE ASFALTO ESTREITO</b>
2	1,100 0,000	<b>5,800</b> <b>0,000</b>		<b>ENTRA TERRA PÔR KM A ZERO DESCE E SEGUE P.P.</b>
3	0,600	<b>0,600</b>		<b>SEGUE P.P.</b>
4	0,200	<b>0,800</b>		<b>SOBE P.P.</b>
5	0,800	<b>1,600</b>		<b>SOBE P.P.</b>
6	0,200	<b>1,800</b>		<b>CONTINUA P.P.</b>
7	0,900	<b>2,700</b>		<b>SOBE P.P.</b>
8	0,800	<b>3,500</b>		<b>CONTINUA P.P.</b>

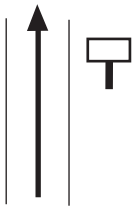
NOTA	PARCIAIS	TOTAIS	DIREÇÃO	OBSERVAÇÕES
1	0,600	4,100		<b>CONTINUA P.P.</b>
2	0,100	4,200		<b>ENTRA ASFALTO E DESCE</b>
3	1,500	5,700		<b>ENTRA E SOBE EMPEDRADO</b>
4	0,400	6,100		
5	0,050	6,150		<b>DESCE E ATRAVESSA PELA RUA PRINCIPAL</b>
6	0,450	6,600		<b>DIR. PRAIA FLUVIAL DA CONGIDA DEPOIS SEGUIR PLACAS DIR. CONGIDA</b>
7	3,700	10,300		<b>PRAIA DA CONGIDA ENTRA EMPEDRADO FIM DA ETAPA</b>
8				